

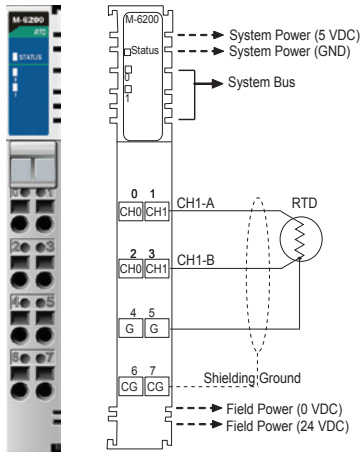

Temperature Input Modules

2-channel temperature input modules, RTD or thermocouple input



M-6200: 2 analog inputs, RTD: PT100, JPT100

Sensor Types:

- PT50, PT100, PT200, PT500, PT1000 (resistance 100 milli-ohms/bit)
- JPT100, JPT200, JPT500, JPT1000 (resistance 10 milli-ohms/bit)
- NI100, NI200, NI500, NI1000, NI120, CU10 (resistance 20 milli-ohms/bit)

Resolution: 0.1°C/10 milli-ohms

Data Format: 16-bit integer (2's complement)

Accuracy:

- ±0.1%, FSR @ 25°C
- ±0.3%, FSR @ 0°C, 60°C

Input Impedance: 500K ohms

Conversion Time: 200 ms for all channels

Diagnostics: Range over (if range over, data=Dx8000)

Power Consumption: Max. 80 mA @ 5 VDC

Isolation: I/O to logic (photocoupler isolation)

Wiring: I/O cable max. AWG14

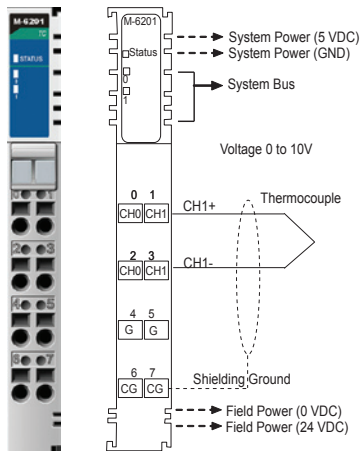

M-6201: 2 analog inputs, thermocouple

Sensor Types:

Type J/K/T/E/R/S/B/N/L/U/C/D
(mV input 10 µV/bit, 2 µV/bit)

Resolution: 0.1°C/10 µV

Data Format: 16-bit integer (2's complement)

Accuracy:

- ±0.1%, FSR @ 25°C
- ±0.3%, FSR @ 0°C, 60°C

Input Impedance: 500K ohms

Conversion Time: 200 ms for all channels

Diagnostics: Range over (if range over, data=Dx8000)

Power Consumption: Max. 80 mA @ 5 VDC

Isolation: I/O to logic (photocoupler isolation)

Wiring: I/O cable max. AWG14



Ordering Information

Analog Input Modules				
Model	M-3802	M-3810	M-6200	M-6201
Channels	8	8	2	2
Current	4 to 20 mA	---	---	---
Voltage	---	0 to 10V	---	---
Connector	RTB	RTB	RTB	RTB
Resolution	12-bit	12-bit	---	---
Isolation	Optical isolation			
Sensor Input	---	---	RTD (ohm)	Thermo-couple (mV)