



# Power Modules

## When to Use a Power Module

### System Power Distributor

The system power expansion module is designed to provide extra power for connected I/O expansion modules. Each NA-4000 series network adaptor can provide 1.5 A @ 5 VDC. If you need more power

for your installed I/O expansion modules, you will need to use an M-7001 module. However, note that the M-7001 can only provide 1.5 A @ 5 VDC.

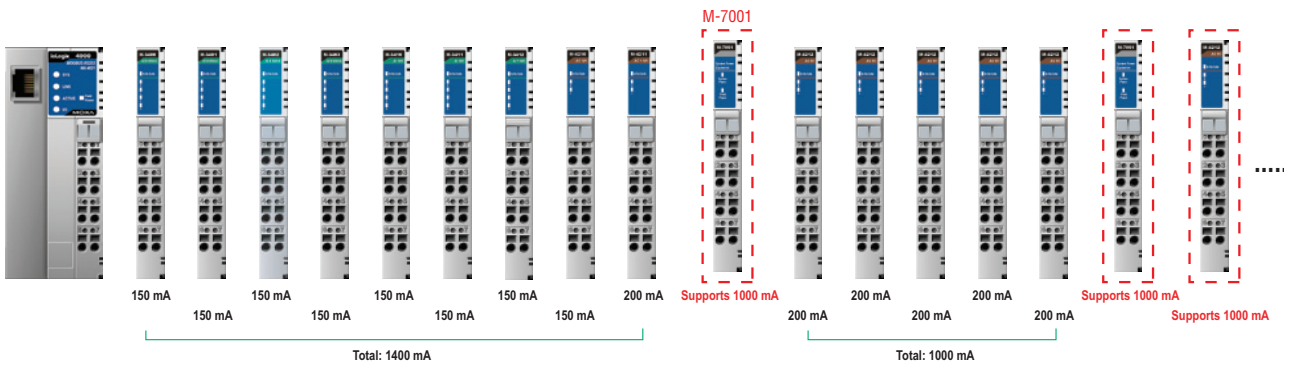

### Field Power Distributor

The field power distributor is designed to isolate different field voltages. For example, before you connect a 48 VDC or 110 VAC DI/O

module to a 24 VDC DI/O module, you will need an M-7002 field power distributor.

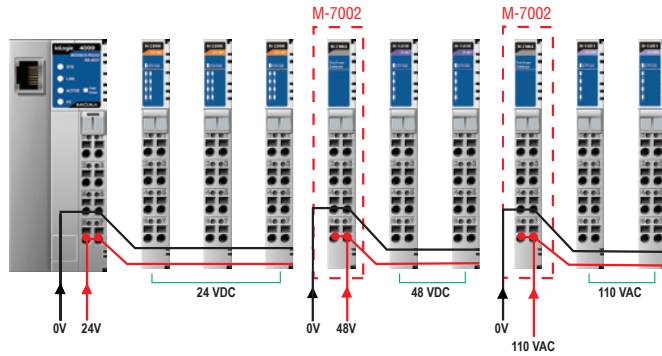

### Potential Power Distributor

There are three types of potential distributor modules that provide extra wiring points, such as shielding ground, 0 V field power, and 24 V field power. For example, the 8-channel digital input (sink type)

module by itself does not have a 24 V wiring point. In this case, you can add an M-7805 for easier wiring.

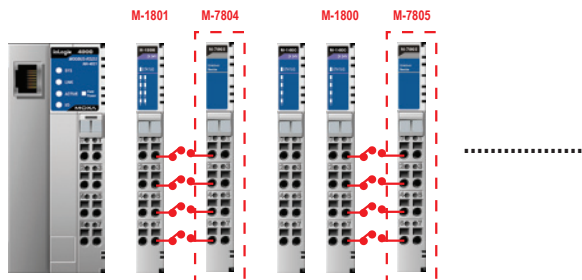

# Power Modules

## M-7001: System power module

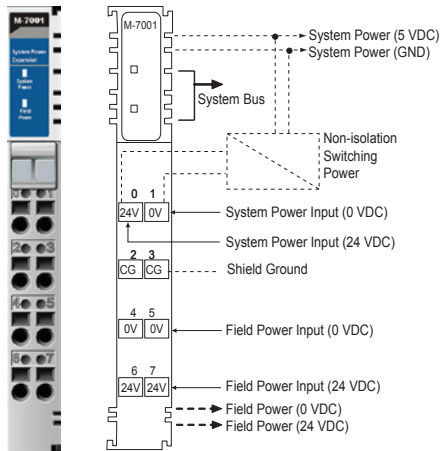

- **System Input Voltage:** 24 VDC, 11 to 28.8 VDC
- **Field Power Input Voltage:** 24 VDC ( $\pm 20\%$ )
- **Current for I/O Modules:** 1.5 A @ 5 VDC (Max.)
- **System Bus Output Voltage:** 5 VDC (Max.)
- **Field Power Contacts Current:** 10 A (Max.)

## M-7002: Field power module

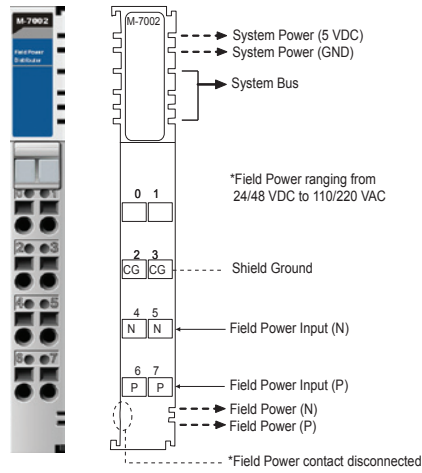

- **Field Power Input Voltage:**  
DC: 5 VDC, 24 VDC, 48 VDC  
AC: 110 VAC, 220 VAC
- **Current for Field Power Contacts:** 10 A (Max.)

## M-7804: 0 VDC

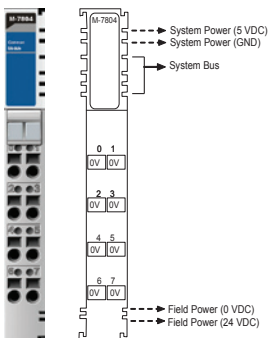

**Channels:** 8  
**Mode:** 0 VDC

## M-7805: 24 VDC

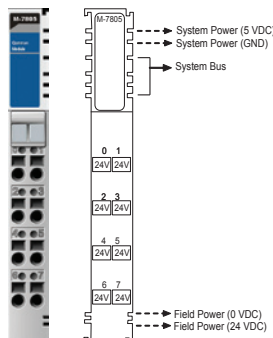

**Channels:** 8  
**Mode:** 24 VDC

## Ordering Information

Power Modules					
Specs	Model	M-7001	M-7002	M-7804	M-7805
	Channels	0	0	8	8
	Voltage	24 VDC	DC: 5, 24, 48 VDC AC: 110/220 VAC	0 VDC	24 VDC
	Purpose	System Power	Field Power	Field Power	Field Power